

## SmartLine Wireless Gauge Pressure Transmitter Models Specification

### Dual Head Gauge Models:

STGW840	0 to 500 psi	0 to 35,000 mbar
STGW870	0 to 3,000 psi	0 to 210,000 mbar

### In-Line Gauge Models:

STGW84L	0 to 500 psi	0 to 35,000 mbar
STGW87L	0 to 3,000 psi	0 to 210,000 mbar

### Introduction

SmartLine Wireless Pressure continues the evolution of Honeywell's wireless transmitter product offering and provides the latest critical advancements to support industrial automation users' desire to expand wireless use for monitoring and control.

With over 14 years of industrial wireless experience, the SmartLine Wireless Pressure builds upon and is compatible with the current XYR 6000 product portfolio. Similar to the XYR 6000 wireless transmitter, the SmartLine Wireless product line is part of the Honeywell OneWireless™ system and is ISA100 - ready.

SmartLine Wireless Pressure transmitters also leverage SmartLine technology in the incorporation of the enhanced SmartLine Pressure meter body. By utilizing the same meter body as in the non-wireless pressure product offering, you get best-in-class performance, reduction in spares inventory, and a lessening of the maintenance learning curve.

The SmartLine Wireless Pressure transmitter enables customers to obtain data and create information from remote and hazardous measurement locations without the need to run wires, where running wire is cost prohibitive and/or the measurement is in a hazardous location. Without wires, transmitters can be installed and operational in minutes, quickly providing information back to your system.



**Figure 1 — SmartLine Wireless Gauge Pressure Transmitters**

The previous generation transmitters primarily were applied to monitoring applications but experienced users know that Honeywell's wireless products are as reliable, secure, and safe as their wired counterparts. With this knowledge, users are now looking for wireless transmitters for use in specific control applications.

SmartLine Wireless introduces a step change in performance and most notably, performance suitable for control. SmartLine Wireless performance is improved in these ways:

- Fast ½ second publication rate
- Built-in additional noise reduction
- More powerful 4 dBi integral antenna
- Good battery life performance even at ½ second publication rate.

SmartLine Wireless Pressure retains the following desirable features from the XYR 6000 product offering:

- Mesh or non-mesh configuration within each transmitter
- Generic, off-the-shelf lithium ion battery.
- Two “D” size batteries for longer life.
- Choice of over-the-air or local provisioning (network security join key)
- Over-the-air firmware upgrade capability
- Unique, encrypted provisioning key delivered from the factory
- Remote and integral antenna options
- 24 VDC power option
- Publication rates of 1, 5, 10, or 30 seconds, plus new selections for ½ sec, and 1, 15, 30, 60 minutes
- Transmitter range (integral antenna) of 1150’ (350 m) under ideal conditions.

The STWG8x0 and STWG8xL are high performance gauge pressure transmitter featuring piezoresistive sensor technology combining pressure sensing with on-chip temperature compensation capabilities thus providing high accuracy, stability and performance over a wide range of application pressures and temperatures.

The SmartLine family is also fully tested and compliant with Experion® PKS providing the highest level of compatibility assurance and integration capabilities. SmartLine easily meets the most demanding application needs for pressure measurement applications.

#### Best in Class Features:

- Accuracy up to 0.055 % of calibrated span
- Stability up to 0.010% of URL per year for ten years
- Automatic temperature compensation
- Rangeability up to 100:1
- Intuitive external zero & span capability
- Integral dual seal design for safety based on ANSI/NFPA 70-202 and ANSI/ISA 12.27.0
- Available with 15-year warranty

#### Span & Range Limits:

Model	URL / Max Span psi (bar)	LRL psi (bar)	Min Span psi (bar)
STGW840	500 (35)	-14.7 (-1.0)	5 (.35)
STGW870	3000 (210)	-14.7 (-1.0)	30 (2.1)
Model	psi (bar)	psi (bar)	psi (bar)
STGW84L	500 (35)	-14.7 (-1.0)	5 (.35)
STGW87L	3000 (210)	-14.7 (-1.0)	30 (2.1)

## SmartLine Wireless Features

**Local and over-the-air provisioning capability.** All Honeywell wireless devices feature a secure method to join the local wireless network, also known as provisioning. SmartLine Wireless transmitters feature two methods to provision a transmitter onto the network which are either by using a handheld device to locally communicate through the IR interface or remotely using the over-the-air function. The over-the-air function is managed by the OneWireless gateway, Wireless Device Manager (WDM).

In either method, the communication of secure, unique provisioning keys is one of the main factors to prevent against unintended access. Honeywell’s security keys are unique for each device from the factory, never made visible, always encrypted, and uniquely generated from the gateway that manages the deployed network.

**Over-the-air firmware updates.** Once joined as a member of your OneWireless network, the WDM can download new transmitter firmware releases to each SmartLine Wireless transmitter over the wireless network. Locating and accessing the transmitter locally is not required thus saving time and keeping your personnel in safe environments.

**Mesh and non-mesh capability.** All SmartLine Wireless transmitters can be configured to operate in either a mesh network or a star (non-mesh) network. The configuration is specific to each wireless transmitter and thus the network can consist of a mixture of meshing and non-meshing devices. Non-meshing is desirable for deterministic communications which is preferred for control.

**Transmission power setting.** To comply with local and regional requirements, SmartLine Wireless transmitters are set at the factory to the maximum transmission power setting allowed for the country of use.

**Non-proprietary battery.** Sourcing lithium thionyl chloride batteries is much simpler since SmartLine Wireless utilizes commercial off-the-shelf batteries. Please see the list of approved battery manufacturers later in this specification. Batteries are housed in an IS-approved battery compartment making battery changes safe and easy.

**Backward compatibility.** SmartLine Wireless transmitters can join existing OneWireless networks and interoperate with existing XYR 6000 wireless transmitters or other ISA100 Wireless compliant transmitters or networks.

## OneWireless Network Features

The core of the Honeywell wireless solution is the OneWireless Network which consists a gateway, access point(s), and field routers.

The Wireless Device Manager (WDM) serves as the gateway function and in this role, manages the communication from the wireless field devices to the process control application. Typically, the WDM connects logically to the process control network (Level 2 or wireless DMZ). As the wireless network manager, the WDM provides easy access to the entire wireless network through a browser-based user interface. The Honeywell WDM can manage devices communicating over the ISA100 Wireless protocol and the Wireless HART™ protocol.

The ability to deploy redundant WDMs improves the reliability ensuring no loss of process data which is a requirement for control applications.

The Field Device Access Point (FDAP) serves in two roles in the OneWireless network infrastructure, which are: 1) access point, and 2) field router. As an access point, the FDAP directly connects to the WDM via Ethernet LAN cable. More than one access point is permitted and, when more than one is present, it ensures dual path for communications into the WDM from the field devices. As a field router, the FDAP located in the field would communicate to the FDAP acting as an access point. Using the FDAP as a router is more efficient than using field devices as routers since FDAPs are line powered devices whereas field devices are typically battery powered, and the FDAP offers greater range. The meshing capability of FDAPs allows flexibility in the setup of the wireless network to fit the requirements for wireless network performance, in terms of reliable communications, performance, and future growth.

The choice of non-meshing network may be desirable for decreased communication latency which a FDAP serving as a field router helps ensures.

## Wireless Specifications

Parameter	Description
<b>Wireless Communication</b>	2,400 to 2,483.5 MHz (2.4 GHz) Industrial, Scientific and Medical (ISM) band DSSS - Direct Sequential Spread Spectrum per FCC 15.247 / IEEE 802.15.4 2006 Every data packet transmitted in either direction is verified (CRC check) and acknowledged by the receiving device. USA – FCC Certified Canada – IC Certified European Union – Radio Equipment Directive compliant
<b>DSSS RF Transmitter Power</b>	NA Selection –100 mW (20.0 dBm) maximum EIRP including antenna for USA and Canadian locations. EU Selection – 63 mW (18.0 dBm) maximum EIRP including antenna per RTTE/ETSI for EU locations. Compliant to ETSI EN 300 328 wireless standard
<b>Data</b>	PV Publish Cycle Time: Configurable as 0.5, 1, 5, 10, 30 seconds, plus 1, 15, 30, 60 minutes Rate: 250 Kbps
<b>Antennas</b>	Integral – 4 dBi omnidirectional monopole (default selection) Remote – 8 dBi omnidirectional monopole with up to two 10 m cables and lightning surge arrester Remote – 14 dBi directional parabolic with up to two 10 m cables and lightning surge arrester.
<b>Signal Range</b>	Nominal 350 m (1150 feet) between field transmitter and infrastructure unit (e.g. FDAP) when using 4 dBi Integral antenna with a clear line of sight*

\*Actual range will vary depending on antennas, cables and site topography.

## Specifications

### Operating Conditions – All Models

Parameter	Reference Condition (at zero static)		Rated Condition		Operative Limits		Transportation and Storage	
	°C	°F	°C	°F	°C	°F	°C	°F
Ambient Temperature <sup>4</sup>	25 ±1	77 ±2	-40 to 85	-40 to 185	-40 to 85	-40 to 185	-55 to 120	-67 to 248
Ambient Temperature LCD Display visible range	25 ±1	77 ±2	-40 to 85	-40 to 185				
Meter Body Temperature	25 ±1	77 ±2	-40 to 110	-40 to 230	-40 to 125	-40 to 257	-55 to 120	-67 to 248
Humidity %RH	10 to 55		0 to 100		0 to 100		0 to 100	
Vacuum Region - Minimum Pressure All Models mmHg absolute in H <sub>2</sub> O absolute	Atmospheric Atmospheric		25 13		2 (short term <sup>1</sup> ) 1 (short term <sup>1</sup> )			
Maximum Allowable Working Pressure (MAWP) <sup>2,3</sup>  (ST700 products are rated to Maximum Allowable Working Pressure. MAWP depends on Approval Agency and transmitter materials of construction.)	STGW840: 500 psi (35 bar) STGW870: 3000 psi (210 bar)  STGW84L: 500 psi (35 bar) STGW87L: 3000 psi (210 bar)							
Over pressure  These are the pressure limits the transmitters can withstand without damage.	STGW840: 1500 psi (103 bar) STGW870: 4500 psi (310 bar)  STGW84L: 1500 psi (103 bar) STGW87L: 4500 psi (310 bar)							
Vibration	Maximum of 4g over 15 to 200Hz.							
Shock	Maximum of 40g.							
Power	Commercially available, non-proprietary 3.6V Lithium thionyl chloride (LiSOCl <sub>2</sub> ) batteries, non-rechargeable, size D. Battery pack-only option is available. Approved list of the manufacturer models: <ol style="list-style-type: none"> <li>1. Xeno Energy XL-205F</li> <li>2. Eagle Picher PT-2300H</li> <li>3. Tadiran TL-5930/s</li> </ol>							
	24 VDC power option. For Non I.S. application: 16 to 28 VDC Input range, max input current 100mA. For I.S. application: Barrier in accordance with the control drawing required, Entity parameters 30V, 120mA, 0.9W							

<sup>1</sup>Short term equals 2 hours at 70°C (158°F)

<sup>2</sup> Units can withstand overpressure of 1.5x MAWP without damage.

<sup>3</sup> Consult factory for MAWP of SmartLine Wireless transmitters with CRN approval.

<sup>4</sup> The Ambient Limits shown are for Ordinary Non-Hazardous locations only. Refer to the Hazardous Locations Approvals section for the Ambient Limits when installed in Hazardous Locations.

**Remote Antenna Cables**

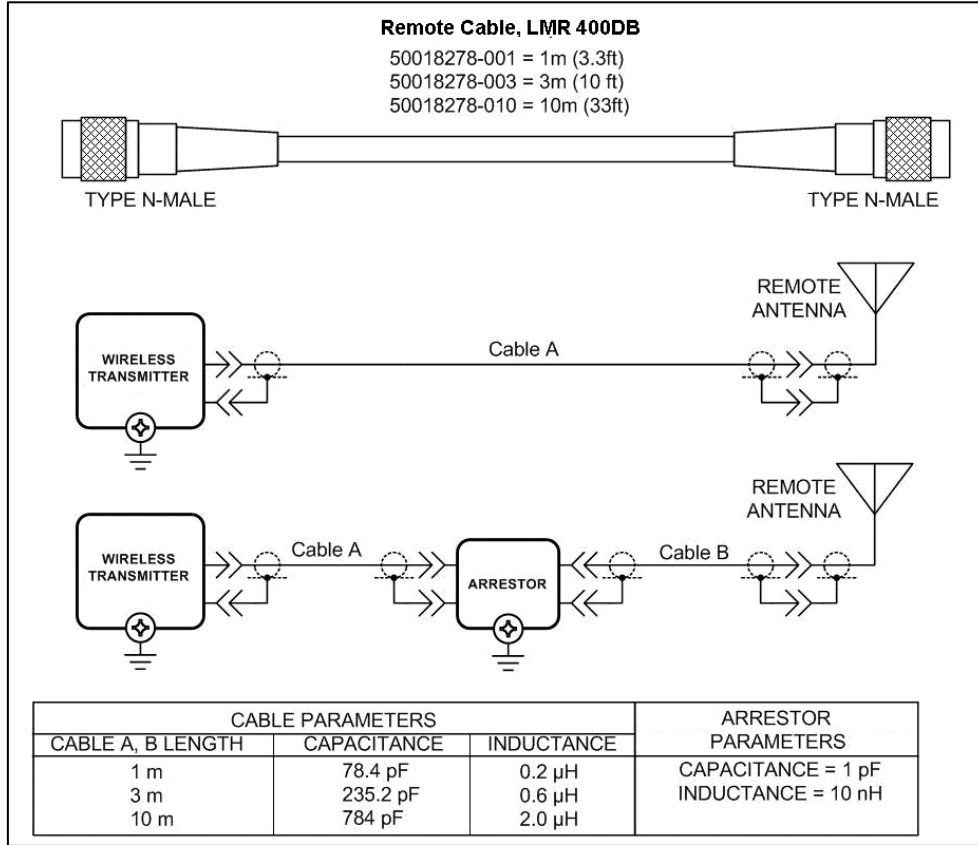

**Remote Antennas**

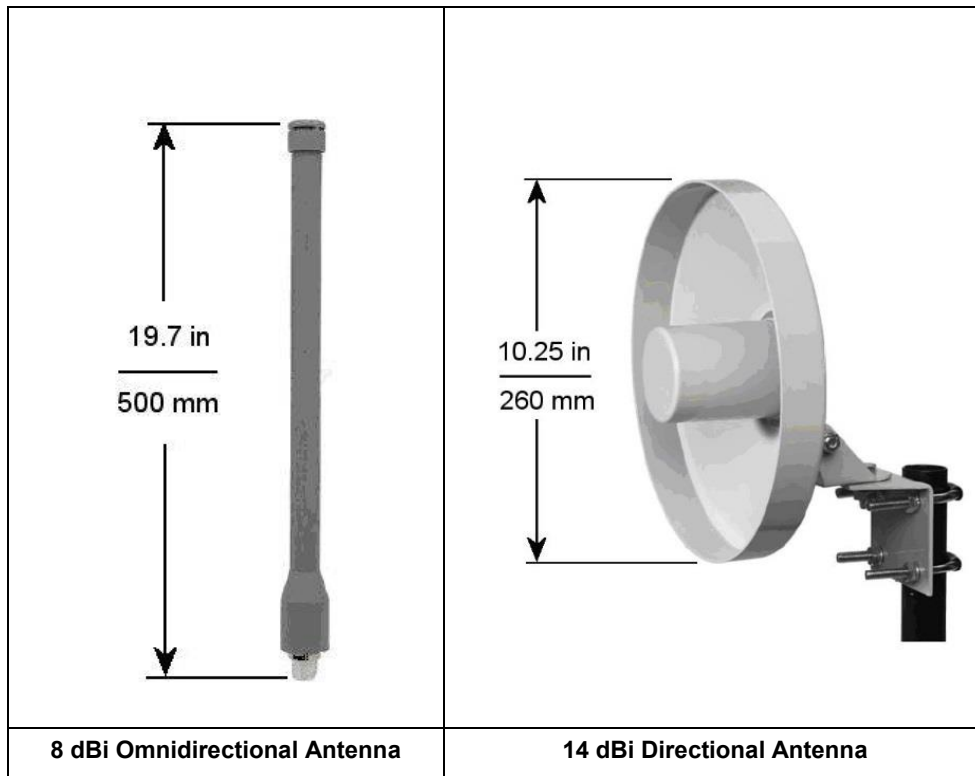

## Performance Specifications

### Performance under Rated Conditions\* - Model STGW840 & STGW84L (0 to 500 psi/35 bar)

Parameter		Description
<b>Upper Range Limit</b>	<b>psi</b> <b>bar</b>	500 35
<b>Minimum Span</b>	<b>psi</b> <b>bar</b>	5 0.35
<b>Zero Elevation and Suppression</b>		<b>No limit except minimum span from absolute 0 (zero) to +100% URL. Specifications valid over this range.</b>
<b>Accuracy</b> (Reference – Includes combined effects of linearity, hysteresis, and repeatability)  Accuracy includes residual error after averaging successive readings.		±0.0625% of calibrated span or upper range value (URV), whichever is greater, terminal based. For URV below reference point (20 psi), accuracy equals:  $\pm \left[ 0.0125 + 0.05 \left( \frac{20 \text{ psi}}{\text{span/ psi}} \right) \right] \text{ or } \pm \left[ 0.0125 + 0.05 \left( \frac{1.4 \text{ bar}}{\text{span/ bar}} \right) \right] \text{ in \% of span}$
<b>Zero Temperature Effect per 28°C (50°F)</b>		±0.05% of span. For URV below reference point (75 psi), effect equals:  $\pm 0.05 \left( \frac{75 \text{ psi}}{\text{span/ psi}} \right) \text{ or } \pm 0.05 \left( \frac{5.25 \text{ bar}}{\text{span/ bar}} \right) \text{ in \% of span}$
<b>Combined Zero and Span Temperature Effect per 28°C (50°F)</b>		±0.075% of span. For URV below reference point (75 psi), effect equals:  $\pm \left[ 0.025 + 0.05 \left( \frac{75 \text{ psi}}{\text{span/ psi}} \right) \right] \text{ or } \pm \left[ 0.025 + 0.05 \left( \frac{5.25 \text{ bar}}{\text{span/ bar}} \right) \right] \text{ in \% of span}$

\* Performance specifications are based on reference conditions of 25°C (77°F), 10 to 55% RH, and 316L Stainless Steel barrier diaphragm.

### Performance under Rated Conditions\* - Model STGW870 & STGW87L (0 to 3,000 psi/210 bar)

Parameter		Description
<b>Upper Range Limit</b>	<b>psi</b> <b>bar</b>	3,000 210
<b>Minimum Span</b>	<b>psi</b> <b>bar</b>	30 2.1
<b>Zero Elevation and Suppression</b>		<b>No limit except minimum span from absolute 0 (zero) to +100% URL. Specifications valid over this range.</b>
<b>Accuracy</b> (Reference – Includes combined effects of linearity, hysteresis, and repeatability)  •Accuracy includes residual error after averaging successive readings.		±0.0625% of calibrated span or upper range value (URV), whichever is greater, terminal based. For URV below reference point (750 psi), accuracy equals:  $\pm \left[ 0.0125 + 0.05 \left( \frac{750 \text{ psi}}{\text{span/ psi}} \right) \right] \text{ or } \pm \left[ 0.0125 + 0.05 \left( \frac{52 \text{ bar}}{\text{span/ bar}} \right) \right] \text{ in \% of span}$
<b>Zero Temperature Effect per 28°C (50°F)</b>		±0.10% of span. For URV below reference point (500 psi), effect equals:  $\pm 0.10 \left( \frac{500 \text{ psi}}{\text{span/ psi}} \right) \text{ or } \pm 0.10 \left( \frac{35 \text{ bar}}{\text{span/ bar}} \right) \text{ in \% of span}$
<b>Combined Zero and Span Temperature Effect per 28°C (50°F)</b>		±0.15% of span. For URV below reference point (500 psi), effect equals:  $\pm \left[ 0.05 + 0.10 \left( \frac{500 \text{ psi}}{\text{span/ psi}} \right) \right] \text{ or } \pm \left[ 0.05 + 0.10 \left( \frac{35 \text{ bar}}{\text{span/ bar}} \right) \right] \text{ in \% of span}$

\* Performance specifications are based on reference conditions of 25°C (77°F), 10 to 55% RH, and 316L Stainless Steel barrier diaphragm.

**Performance Under Rated Conditions – All Models**

Parameter	Description
<b>Electromagnetic Compatibility</b>	IEC 61326-1
<b>Lightning Surge Arrester (Remote antenna only)</b>	Frequency range: 0 – 3 GHz, 50 Ohms, VSWR = 1:1.3 Max, Insertion Loss = 0.4 dB Connectors Type N Female, Max, Gas Tube Element: 90 V ± 20%, Impulse Breakdown Voltage = 1,000 V ± 20%, Maximum Withstand Current = 5 KA.
<b>CE Conformity</b>	These transmitters are in conformity with the Radio Equipment Directive, ETSI EN 300 328 V2.1.1 including EMC standard EN61326-1 2013

**Physical Specifications**

Parameter	Description
<b>Mounting Bracket</b>	Carbon Steel (zinc-plated) or Stainless Steel angle bracket or flat bracket available.
<b>Electronic Housing</b>	Epoxy-Polyester hybrid paint. Low Copper-Aluminum with 1/2" NPT or M20 conduit connections. Meets NEMA 4X (hosedown and corrosion resistant), IP 66/67 (hosedown and submersible to 1m).
<b>Stainless Steel Housing (option)</b>	316 SS or Grade CF8M, the casting equivalent of 316 SS with M20 or 1/2" NPT conduit connections. If ordered with the Remote Antenna options, the antenna parts are not SS or Marine type cables; the integral antenna uses SS parts.
<b>Process Connections</b>	1/4-inch NPT; 1/2-inch NPT with adapter. Process heads meet DIN 19213 requirements.
<b>Mounting</b>	Can be mounted in virtually any position using the standard mounting bracket. Mounting should result in the antenna being vertically oriented. Bracket is designed to mount on 2-inch (50 mm) vertical or horizontal pipe. See <a href="#">Figure 2</a> and <a href="#">Figure 3</a> .
<b>Dimensions</b>	See <a href="#">Figure 4</a> , <a href="#">Figure 5</a> , <a href="#">Figure 6</a> , <a href="#">Figure 7</a> , <a href="#">Figure 8</a> and <a href="#">Figure 9</a> .
<b>Net Weight</b>	Approximately 11 pounds (5 Kg) for STGW8X0, and 7 pounds (3.2 kg) for STGW8XL <sup>1</sup>

<sup>1</sup> Add 8.0 pounds (3.6 kg) to any model equipped with stainless steel housing option (Model Selection Guide Table IV selection M or N)

**Materials Specifications (see model selection guide for availability/restrictions with various models)**

Parameter	Description
<b>Barrier Diaphragms Material</b>	<b>STGW800 Dual Head:</b> 316L SS, Hastelloy® C-276 <sup>2</sup> <b>STGW800 In-Line:</b> 316L SS, Hastelloy® C-276 <sup>2</sup>
<b>Process Head Material</b>	<b>STGW800 Dual Head:</b> 316 SS <sup>3</sup> <b>STGW800 In-Line:</b> 316L SS
<b>Vent/Drain Valves &amp; Plugs <sup>1</sup></b>	<b>STGW800 Dual Head:</b> 316 SS <sup>3</sup> <b>STGW800 In-Line:</b> N/A
<b>Head Gaskets</b>	<b>STGW800 Dual Head:</b> Glass-filled PTFE standard. <b>STGW800 In-Line:</b> N/A
<b>Meter Body Bolting</b>	<b>STGW800 Dual Head:</b> Carbon Steel (Zinc plated) standard. Options include 316 SS, NACE A286 SS bolts and nuts. <b>STGW800 In-Line:</b> N/A
<b>Fill Fluid</b>	Silicone DC 200 oil, NEOBEE M-20, or CTFE (Chlorotrifluoroethylene)

<sup>1</sup> Vent/Drains are sealed with Teflon®

<sup>2</sup> Hastelloy C-276 or UNS N10276

<sup>3</sup> Supplied as 316 SS or as Grade CF8M, the casting equivalent of 316 SS.

## Mounting information

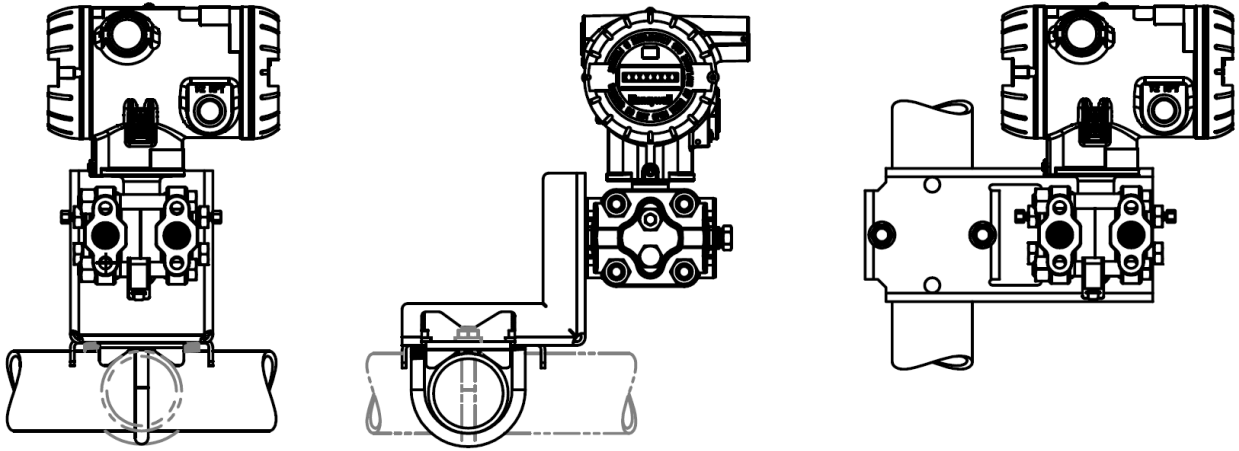

Figure 2: Dual Head Gauge, examples of typical mounting positions (antenna omitted)

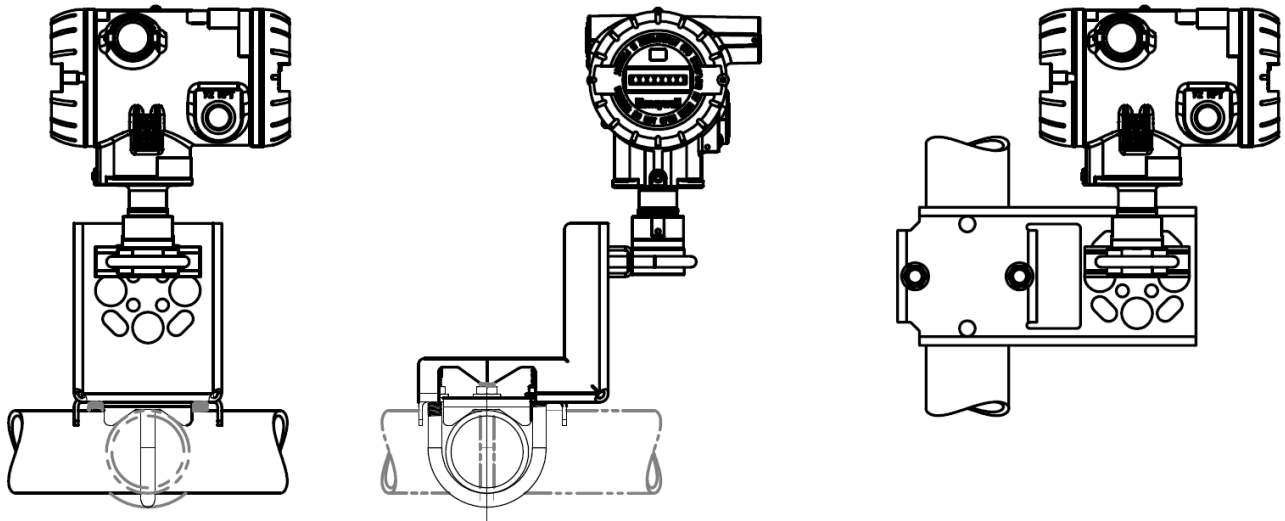

Figure 3: In-Line Gauge, examples of typical mounting positions (antenna omitted)

**Dimensions**

Reference Dimensions:  $\frac{\text{millimeters}}{\text{inches}}$

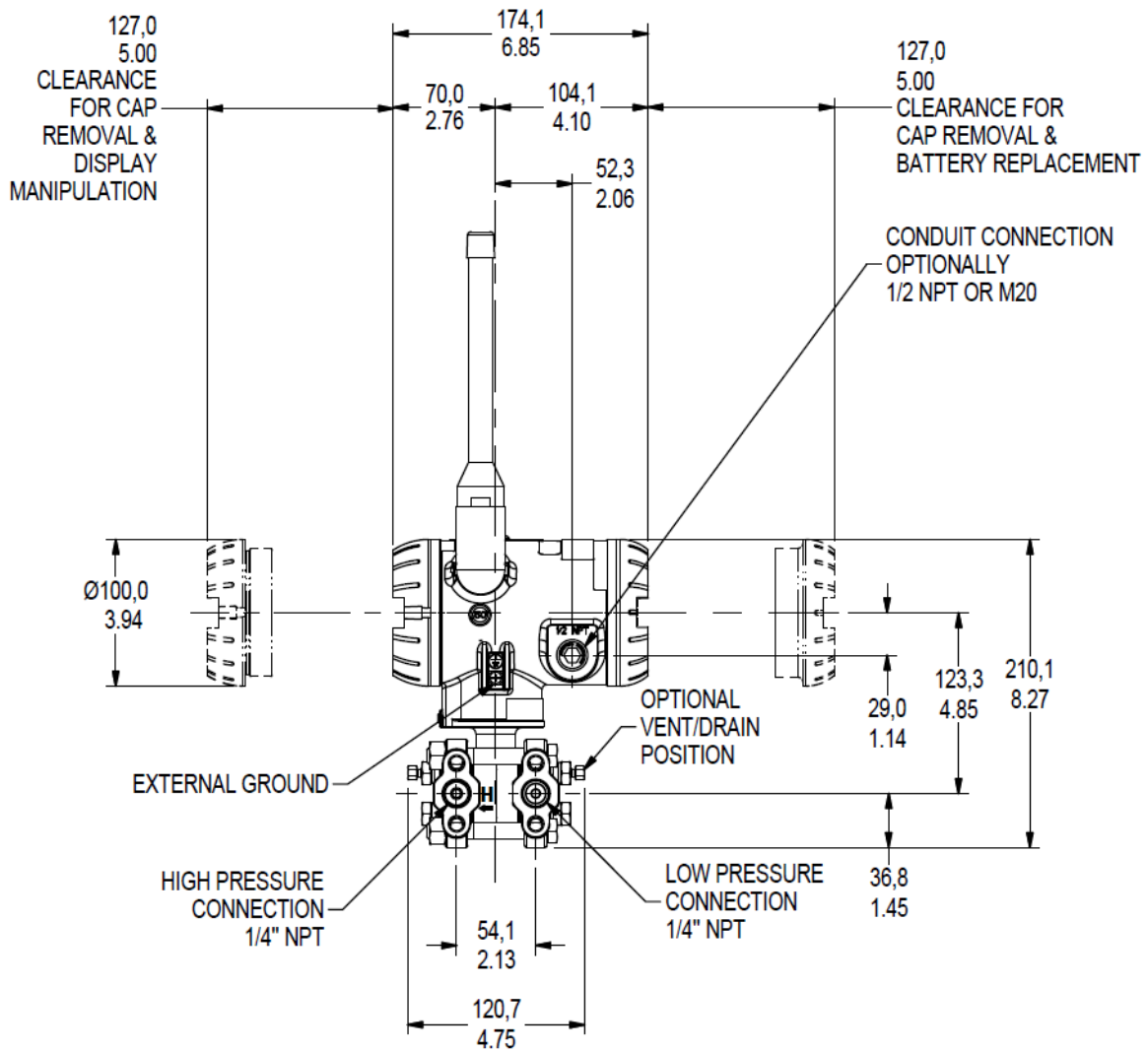

Figure 4 – Dual Head Gauge, Informational and dimensional drawing (4 dBi antenna shown)

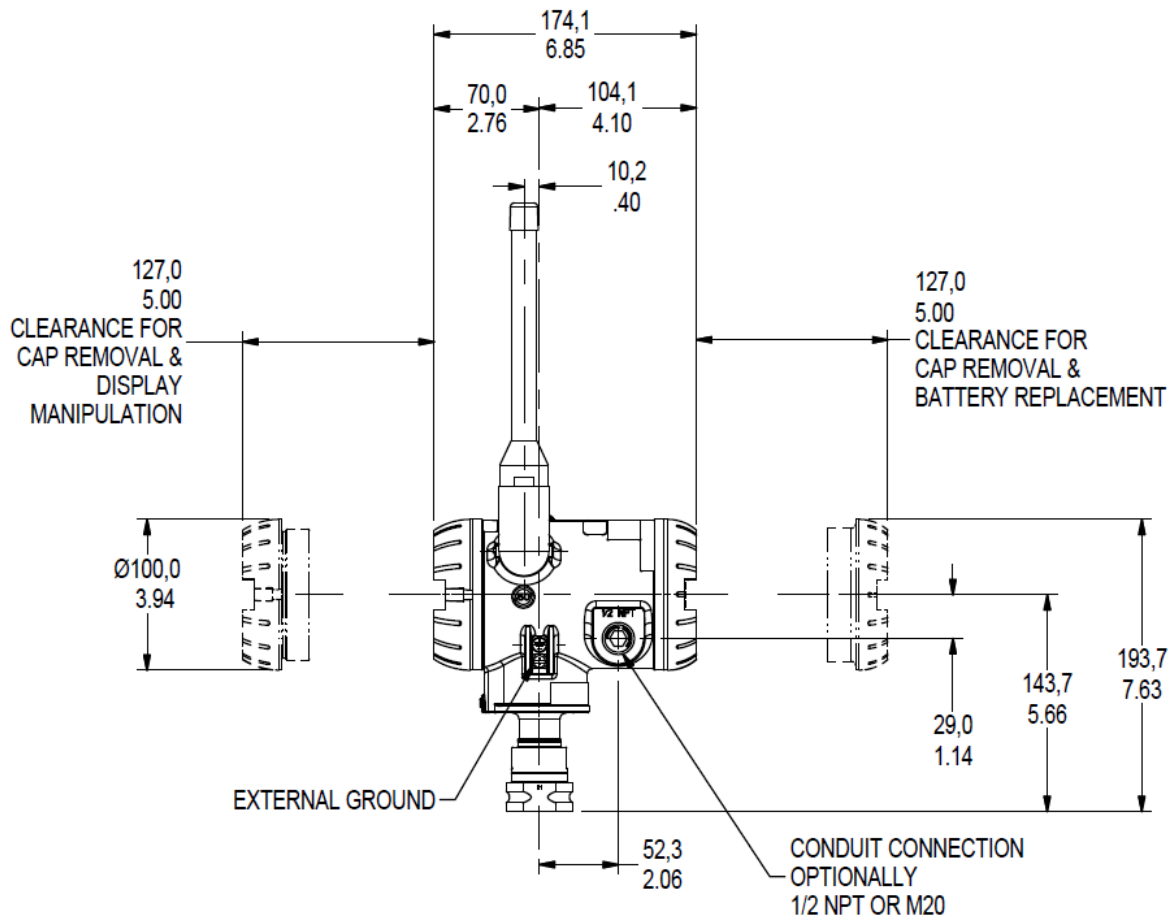

Figure 5 – In-Line Gauge, Informational and dimensional drawing (4 dBi antenna shown)

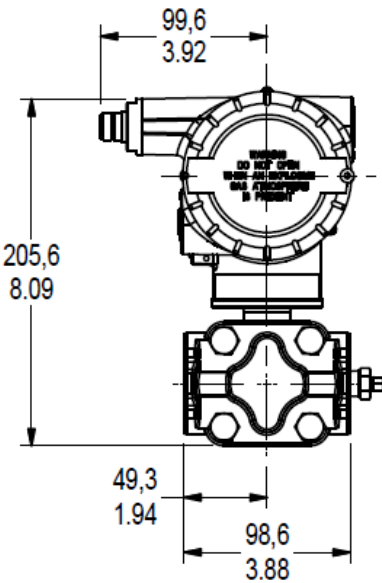

Figure 6: Dual Head Gauge, typical mounting dimensions for STGW840, STGW870 (remote adaptor shown)

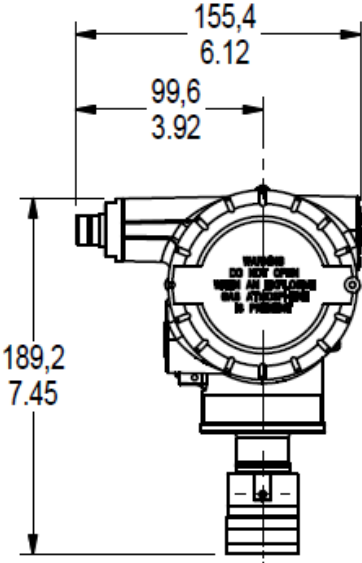

Figure 7: In-Line gauge, typical mounting dimensions for STGW84L, STGW87L (remote adaptor shown)

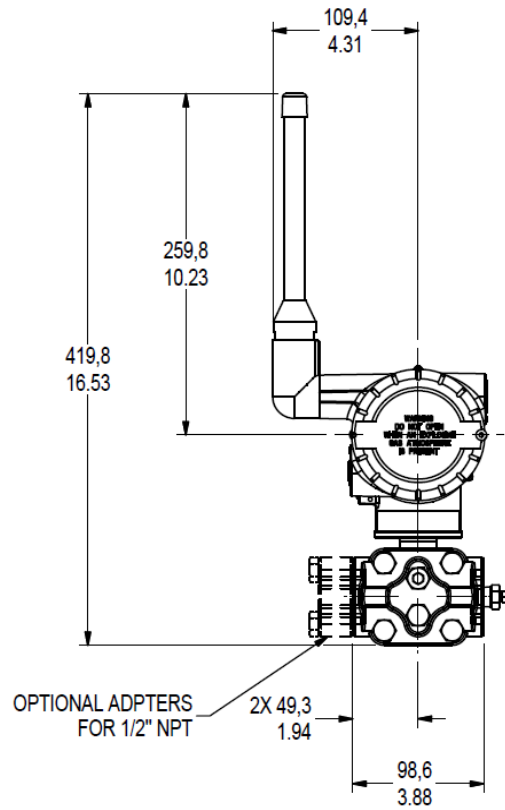

Figure 8: Dual Head Gauge, typical mounting dimensions for STGW840, STGW870 (4 dBi antenna shown)

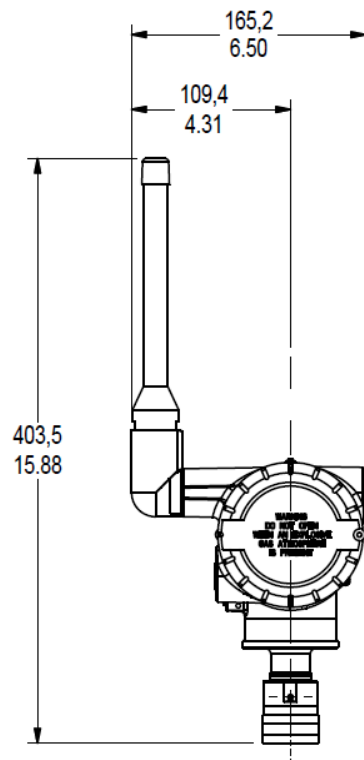

Figure 9: In-Line Gauge, typical mounting dimensions for STGW84L, STGW87L (4 dBi antenna shown)

## Hazardous Locations Approvals

Refer to control drawing 50136123, in the User's manual #34-SW-25-01, for intrinsically safe installation details

AGENCY	TYPE OF PROTECTION	Ambient Temperature
<b>CSA  (USA and Canada)</b>	<b>Intrinsically Safe:</b> Class I; Division 1; Groups A, B, C, D; Class II, Division 1, Groups E, F, G; Class III, Division 1; T4 Class I, Zone 0 AEx ia IIC T4 Ga Class I Zone 2 AEx ic IIC T4 Gc Ex ia IIC T4 Ga Ex ic IIC T4 Gc	See tables below
	<b>Nonincendive:</b> Class I; Division 2; Groups A, B, C, D; Class II, Division 2, Groups E, F, G; Class III, Division 2, T6...T4 Ex nA [ia] IIC T6...T4 Gc [Ga] Class I, Zn 2[0], AEx nA[ia] IIC T6...T4 Gc[Ga]	See tables below
	<b>Explosion-Proof/ Flameproof/Dust Proof:</b> Class I, Division 1; Groups A, B, C, D; Class II, Division 1, Groups E, F, G; Class III, Division 1; T6...T4 Ex db [ia] IIC T6...T4 Gb[Ga] Ex tb [ia] IIIC T95...T125 Db[Da] Class I, Zn 1[0] AEx db [ia] IIC T6...T4 Gb[Ga] Class II, Zn 21, AEx tb[ia] IIIC T95...T125 Db[Da]	See tables below
	<b>Enclosure:</b> Type 4X/ IP66/ IP67	

AGENCY	TYPE OF PROTECTION	Ambient Temperature
<b>FM Approvals™ (USA)</b>	<b>Intrinsically Safe:</b> IS Class I, II, III; Division 1; Groups ABCDEFG; T4 Class I, Zone 0 AEx ia IIC Ga T4 Class I, Zone 2[0] AEx ic [ia Ga] IIC Gc T4	-40 °C to +85 °C
	<b>Nonincendive:</b> NI-AIS Class I; DIV 2; Groups ABCD; T5..T6 Class I, Zone 2[0] AEx nA [ia Ga] IIC Gc, T5..T6	-40 °C to +85 °C : T5 -40 °C to +70 °C : T6
	<b>Dust Proof:</b> DIP-AIS Class II, III DIV 1, Groups EFG; T5..T6 Zone 21[20] AEx tb [ia Da] IIIC T95°C Db	-40 °C to +85 °C : T5, T95°C -40 °C to +70 °C : T6
	<b>Enclosure:</b> Type 4X/ IP66/ IP67	

AGENCY	TYPE OF PROTECTION	Ambient Temperature
ATEX	<b>Intrinsically Safe:</b> II 1 G Ex ia IIC T4 Ga II 3 G Ex ic IIC T4 Gc	-40 ° C to +85 ° C
	<b>Flameproof / Dust Proof:</b> II 2[1] G Ex d [ia] IIC T6..T5 Gb[Ga] II 2[1] D Ex tb [ia] IIIC T95C Db[Da]	-40 ° C to +85 ° C : T5, T95C -40 ° C to +70 ° C : T6
	<b>Nonincendive:</b> II 3[1] G Ex ec [ia] IIC T6..T5 Gc[Ga]	-40 ° C to +85 ° C : T5 -40 ° C to +70 ° C : T6
	Enclosure: IP66/ IP67	

AGENCY	TYPE OF PROTECTION	Ambient Temperature
IECEx	<b>Intrinsically Safe:</b> Ex ia IIC T4 Ga Ex ic IIC T4 Gc	-40 ° C to +85 ° C
	<b>Flameproof / Dust Proof:</b> Ex db [ia] IIC T6..T5 Gb[Ga] Ex tb [ia] IIIC Db[Da] T95C	-40 ° C to +85 ° C : T5, T95C -40 ° C to +70 ° C : T6
	<b>Nonincendive:</b> Ex ec [ia] IIC T6..T5	-40 ° C to +85 ° C : T5 -40 ° C to +70 ° C : T6
	Enclosure: IP66/ IP67	

The applicable temperature class, ambient temperature (Ta) and process temperature (Tp) range of the equipment when installed with type protection “Ex ia” is as follows:

Protection Type	Temperature Class
	T4
Ex ia	Ta = -40 to 80°C Tp = -40 to 125°C
Ex ic	Ta = -40 to 85°C Tp = -40 to 125°C

**For Flameproof, Dustproof, Increased Safety, and Nonincendive Installations:**

The applicable temperature class, ambient temperature (Ta) and process temperature (Tp) range of the equipment when installed with type protection “Ex db”, “Ex ec”, “Ex nA” is as follows:

Protection Type	Temperature Class		
	T4	T5	T6
Ex db	Ta = -40 to 85°C	Ta = -40 to 85°C	Ta = -40 to 75°C
Ex ec	Tp = -40 to 125°C	Tp = -40 to 95°C	Tp = -40 to 80°C
Ex nA			

The applicable temperature class, ambient temperature (Ta) and process temperature (Tp) range of the equipment when installed with type protection “Ex tb” is as follows:

Protection Type	Temperature Class	
	T125C	T95C
Ex tb	Ta = -40 to 85°C Tp = -40 to 125°C	Ta = -40 to 85°C Tp = -40 to 95°C

---

## **Transmitter Options** **(indicated selection code is shown)**

### ***ISA100 Wireless Release Selections (A or B)***

OneWireless R2xx represents the previous releases whereas R3xx is the current release. A OneWireless system with R3xx firmware can host R2xx and R3xx devices. Please select the option to match the targeted OneWireless system.

### ***Remote Antenna and Cables (M or D)***

The user can select one of the optional remote antennas listed. The selection of the antenna option automatically includes the remote antenna adapter.

To complete the option selection, one of the remote antenna cables (1, 2, or 3) must also be selected.

### ***Lightning (Surge) Diverter and Cables (1, 2, or 3)***

The lightning surge diverter options includes the surge diverter and cable. The diverter features Type N connections (female) on both ends. The remote antenna adapter is not included.

### ***Remote Antenna Adapter (A)***

This option provides an adapter to be inserted into the opening where the integral antenna normally connects. The adapter is designed to connect to a remote antenna that the user supplies. It features a female Type N connection.

### ***Standard Diagnostics plus Anti-Alias Filter (3)***

This option enables the Anti-Alias filter option which attenuates the higher frequencies and helps to prevent aliasing components from being sampled.

### ***Destination Country (CA, EU, or US)***

This selection sets the transmission power at the factory to comply with the installation country location.

### ***Custom Configuration (C)***

Customer specified configuration parameters are programmed into the transmitter at the factory. Configuration information needs to be communicated to Honeywell Order Management at time of order entry.

Additionally, the Honeywell OneWireless user interface is accessible through any browser and thus all configurable parameters are visible and can be edited.

### ***Custom Calibration (B)***

Custom calibration would input customer specified LRV and URV values, and check linearity. LRV and URV information needs to be communicated to Honeywell Order Management at time of order entry.

### ***Mounting Brackets (1, 3, 5, or 7)***

The angle mounting bracket is available in either zinc-plated carbon steel or 316 stainless steel and is suitable for horizontal or vertical mounting on a two-inch (50 millimeter) pipe, as well as wall mounting.

An additional flat mounting bracket is also available in carbon steel and 316 stainless steel for two-inch (50 millimeter) pipe mounting.

### ***Tagging (Option 1 or 2)***

The choice of 1 or 2 stainless steel wired-on tags is available. Each tag can accommodate additional data of up to 4 lines of 28 characters. The number of characters includes spaces.

Note that the standard nameplate on the meter body contains the serial number and body-related data.

---

**Model Selection Guide**

Model Selection Guides are subject to change and are inserted into the specifications as guidance only.

**Model STGW800  
Wireless Gauge Pressure Transmitters**

Model Selection Guide  
34-SW-16-34 Issue 1

**Instructions:** Make selections from all Tables using column below the proper arrow. Asterisk indicates availability. Letter (a) refers to restrictions highlighted in the restrictions table. Tables delimited with dashes.

Key	I	II	III	IV	V	VI	VII	VIII	IX
STGW	-	-	-	-	-	-	-	-	00000

KEY NUMBER	URL/Max Span	LRL	Min Span	Units
Gauge	500 (35)	-14.7 (-1.0)	5 (.35)	psi (bar)
Dual Head	3000 (210)	-14.7 (-1.0)	30 (2.1)	psi (bar)
Gauge	500 (35)	-14.7 (-1.0)	5 (.35)	psi (bar)
In-Line	3000 (210)	-14.7 (-1.0)	30(2.1)	psi (bar)

Selection	Availability			
STGW840	↓	↓		
STGW870		↓		
STGW84L			↓	↓
STGW87L				↓

TABLE I	METER BODY SELECTIONS			
a. Process Head & Diaphragm	Process Head/Reference Head Material <sup>1a</sup>		Barrier Diaphragm Material	
	316 Stainless Steel / 316 Stainless Steel		316L SS Hastelloy C - 276	
b. Fill Fluid	Silicone Oil 200 Fluorinated Oil CTFE NEOBEE <sup>®</sup> M-20			
c. Process Connection	Size/Type		Material	
	1/2" NPT (female)		Same as Process Head <sup>1a</sup>	
	1/2" NPT (male)		Same as Process Head	
	DIN 19213 (1/4" female NPT)		Same as Process Head	
G 1/2 B Threaded Fitting		Same as Process Head		
d. Bolt/Nuts Materials	None			
	Carbon Steel			
	316 SS Grade 660 (NACE A286) Bolts & Nuts			
e. Vent/Drain Type/Location	Head Type	Vent Type	Location	Vent Material
	None	None	None	None
	Single Ended	None	None	None
	Single Ended	Standard Vent	Side	Matches Head Material <sup>1</sup>
	Single Ended	Center Vent	Side	Stainless Steel Only
	Dual Ended	Standard Vent	End	Matches Head Material <sup>1</sup>
	Dual Ended	Center Vent	End	Stainless Steel only
Dual Ended	Std Vent/Plug	Side/End	Matches Head Material <sup>1</sup>	
f. Gasket Materials	None			
	Teflon <sup>®</sup> or PTFE (Glass Filled)			

E	*	*	*	*
F	*	*	*	*
1	*	*	*	*
2	*	*	*	*
4	*	*	*	*

G	*	*	*	*
H	*	*	*	*
D	*	*	*	*
B	*	*	*	*
0	*	*	*	*
C	*	*	*	*
S	*	*	*	*
K	p	p	*	*

0	*	*	*	*
1	*	*	*	*
2	*	*	*	*
3	*	*	*	*
4	*	*	*	*
5	*	*	*	*
6	*	*	*	*
0	*	*	*	*
A	*	*	*	*

<sup>1</sup> Except Carbon Steel Heads shall use 316SS Vent/Drain & Plugs and or 1/2" adapters  
<sup>1a</sup> STGW840,870 supplied via 1/2" flange adapter same material as process head except carbon steel shall use 316 SS  
<sup>1b</sup> Reference head available with Dual Head Gage models only. In-Line Gage models are supplied with Process Head only.

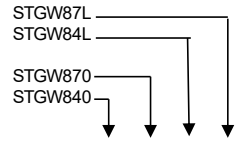

TABLE II		METER BODY & CONNECTION ORIENTATION	
Head / Connect Orientation	Standard	High Side Left, Low Side Right <sup>2</sup> / Std Head Orientation	
	Reversed	Low Side Left, High Side Right <sup>2</sup> / Std Head Orientation	
	90 / Standard	High Side Left, Low Side Right <sup>2</sup> / 90° Head Rotation	

1	*	*	*	*
2	*	*	*	*
3	h	h	*	*

TABLE III		AGENCY APPROVALS	
Approvals	No Approvals Required		
	ATEX and IEC Ex Explosion proof, Intrinsically Safe, Non-incendive & Dustproof		
	c CSA US Explosion proof, Intrinsically Safe, Non-incendive, & Dustproof		
	FM Intrinsically Safe, Non-incendive and Dustproof		

0	*	*	*	*
A	*	*	*	*
B	*	*	*	*
H	*	*	*	*

TABLE IV		TRANSMITTER ELECTRONICS SELECTIONS		
a. Electronic Housing Material & Connection Type	Material	Connection	Paint Color	
	Epoxy Polyester Hybrid Coated Aluminum	1/2 NPT	Standard (Blue / Gray)	
	Epoxy Polyester Hybrid Coated Aluminum	M20	Standard (Blue / Gray)	
	316 Stainless Steel (Grade CF8M)	1/2 NPT	Standard (no paint)	
	316 Stainless Steel (Grade CF8M)	M20	Standard (no paint)	
b. Output/ Protocol	Wireless Protocol			
	ISA100 Wireless 2.0 compatible (equivalent OW R300 or newer) ISA100 Wireless 1.0 compatible (equivalent to OW R2xx)			
c. Power	Power Options			
	Battery Holder Only - No Battery Included			
	Battery Power - Batteries included 24 VDC power			
d. Antennas	Antenna Options			
	Integral Right-angle, vertical 4 dBi			
	Remote Omnidirectional, 8 dBi			
	Remote Directional, 14 dBi Remote Antenna Adapter only, Type N connection			
e. Remote Antenna Cable	Remote Antenna Cable			
	None			
	Type N Remote Cable, 1.0 m (required for connection to transmitter)			
	Type N Remote Cable, 3.0 m (required for connection to transmitter) Type N Remote Cable, 10.0 m (required for connection to transmitter)			
f. Surge Diverter and Cable	Lightning Surge Diverter and Remote Cable			
	None			
	Surge Diverter and Type N Cable (1.0 m)			
	Surge Diverter and Type N Cable (3.0 m) Surge Diverter and Type N Cable (10.0 m)			

C	---	*	*	*	*
D	---	*	*	*	*
M	---	*	*	*	*
N	---	*	*	*	*

A	---	*	*	*	*
B	---	*	*	*	*

0	---	*	*	*	*
B	---	*	*	*	*
D	---	*	*	*	*

R	---	*	*	*	*
M	---	*	*	*	*
D	---	*	*	*	*
A	---	*	*	*	*

0	---	*	*	*	*
1	---	*	*	*	*
2	---	*	*	*	*
3	---	*	*	*	*

0	---	*	*	*	*
1	---	*	*	*	*
2	---	*	*	*	*
3	---	*	*	*	*

TABLE V		CONFIGURATION SELECTIONS	
a. Application Software	Diagnostics and Applications		
	Standard Diagnostics Standard Diagnostics plus Anti-Alias Filter		
b. Country	Destination Country		
	Canada		
	European Union USA and Puerto Rico		
c. General Configuration	General Configuration		
	Factory Standard Custom Configuration (Unit Data Required from customer)		

1	---	*	*	*	*
3	---	*	*	*	*

CA	---	*	*	*	*
EU	---	*	*	*	*
US	---	*	*	*	*

S	---	*	*	*	*
C	---	*	*	*	*

TABLE VI CALIBRATION & ACCURACY SELECTIONS			
a. Accuracy and Calibration	Accuracy	Calibrated Range	Calibration Qty
	Standard	Factory Standard	Single Calibration
	Standard	Custom (Unit Data Required)	Single Calibration

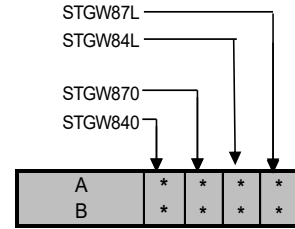

TABLE VII ACCESSORY SELECTIONS		
a. Mounting Bracket	Bracket Type	Material
	None	None
Angle Bracket	Angle Bracket	Carbon Steel
Angle Bracket	Angle Bracket	316 SS
Flat Bracket	Flat Bracket	Carbon Steel
Flat Bracket	Flat Bracket	316 SS
b. Customer Tag	Customer Tag Type	
	No customer tag	
	One Wired Stainless Steel Tag (Up to 4 lines 26 char/line)	
Two Wired Stainless Steel Tag (Up to 4 lines 26 char/line)		
c. Unassembled Conduit Plugs & Adapters	Unassembled Conduit Plugs & Adapters	
	No Conduit Plugs or Adapters Required	
	1/2 NPT Male to 3/4 NPT Female 316 SS Certified Conduit Adapter	
	1/2 NPT 316 SS Certified Conduit Plug	
	M20 316 SS Certified Conduit Plug	
	Minifast® 4 pin (1/2 NPT) (not suitable for X-Proof applications)	
Minifast® 4 pin (M20) (not suitable for X-Proof applications)		

0	*	*	*	*
1	*	*	*	*
3	*	*	*	*
5	*	*	*	*
7	*	*	*	*

_0	*	*	*	*
_1	*	*	*	*
_2	*	*	*	*

_A0	*	*	*	*
_A2	n	n	n	n
_A6	n	n	n	n
_A7	m	m	m	m
_A8	n	n	n	n
_A9	m	m	m	m

TABLE VIII OTHER Certifications & Options: (String in sequence comma delimited (XX, XX, XX,...))	
Certifications & Warranty	No additional options
	NACE MR0175; MR0103; ISO15156 (FC33338) Process wetted parts only
	NACE MR0175; MR0103; ISO15156 (FC33339) Process wetted and non-wetted parts
	EN10204 Type 3.1 Material Traceability (FC33341)
	Certificate of Conformance (F3391)
	Calibration Test Report & Certificate of Conformance (F3399)
	Certificate of Origin (F0195)
	Over-Pressure Leak Test Certificate (1.5X MAWP) (F3392)
	Cert Clean for O <sub>2</sub> or CL <sub>2</sub> service per ASTM G93
	PMI Certification <sup>1</sup>
	Extended Warranty Additional 1 year
	Extended Warranty Additional 2 years
	Extended Warranty Additional 3 years
	Extended Warranty Additional 4 years
	Extended Warranty Additional 15 years

00	*	*	*	*
FG	*	*	*	*
F7	c	c	c	c
FX	*	*	*	*
F3	*	*	*	*
F1	*	*	*	*
F5	*	*	*	*
TP	*	*	*	*
OX	e	e	e	e
PM	*	*	*	*
01	*	*	*	*
02	*	*	*	*
03	*	*	*	*
04	*	*	*	*
15	*	*	*	*

TABLE IX Manufacturing Specials	
Factory	Factory Identification

00000	*	*	*	*
-------	---	---	---	---

**RESTRICTIONS**

Restriction Letter	Available Only with		Not Available with	
	Table	Selection(s)	Table	Selection(s)
c	Id	0,K		
e	Ib	2		
h			Ie VIa	4, 5, 6 1,3,5,7
m	IVa	B, D, N		
n	IVa	A, C, M		
p			III	B- No CRN number available
b	Select Only one option from this group			

<sup>1</sup>The PM option is available on all Smartline Pressure Transmitter process wetted parts such as process heads, flanges, bushings and vent plugs except plated carbon steel process heads and flanges. PM option information is also available on diaphragms except STG and STA in-line construction pressure transmitters.

**FIELD INSTALLABLE ACCESSORY KITS**

Description	Kit Number
1/2 NPT socket plug (ZN plated CS)	50021832-501
1/2 NPT certified conduit plug (SS)	50021832-502
M20 conduit plug (ZN plated CS)	50000547-502
M20 certified conduit plug (SS)	50000547-501
Lightning surge diverter (order cable separately)	50018279-590
IS battery pack	50047517-501
24 VDC external power module	50136118-501
Integral right-angle, vertical 4 dBi, aluminum pure polyester	50030973-503
Integral right-angle, vertical 4 dBi, aluminum epoxy-polyester	50030973-504
Integral right-angle, vertical 4 dBi, stainless steel	50030973-505
Remote omnidirectional antenna, 8 dBi	50018414-501
Remote directional antenna, 14 dBi	50018415-501
Remote antenna adapter, Type N connection	50028364-501
Remote cable for antenna or accessories, Type N (1.0m)	50018278-501
Remote cable for antenna or accessories, Type N (3.0m)	50018278-503
Remote cable for antenna or accessories, Type N (10.0m)	50018278-510
Lithium thionyl chloride batteries (Qty 2)	50026010-501
Lithium thionyl chloride batteries (Qty 4)	50026010-502
Lithium thionyl chloride batteries (Qty 10)	50026010-503

Note P - For part number pricing please refer to WEB Channel

**PRODUCT MANUALS**

Description	Part Number
SmartLine Wireless Transmitter User's Manual	34-SW-25-01

All product documentation is available at [www.honeywellprocess.com](http://www.honeywellprocess.com).

## Sales and Service

For application assistance, current specifications, ordering, pricing, and name of the nearest Authorized Distributor, contact one of the offices below.

### ASIA PACIFIC

Honeywell Process Solutions,  
Phone: + 800 12026455 or  
+44 (0) 1202645583  
(TAC) [hfs-tac-support@honeywell.com](mailto:hfs-tac-support@honeywell.com)

#### Australia

Honeywell Limited  
Phone: +(61) 7-3846 1255  
FAX: +(61) 7-3840 6481  
Toll Free 1300-36-39-36  
Toll Free Fax:  
1300-36-04-70

#### China – PRC - Shanghai

Honeywell China Inc.  
Phone: (86-21) 5257-4568  
Fax: (86-21) 6237-2826

#### Singapore

Honeywell Pte Ltd.  
Phone: +(65) 6580 3278  
Fax: +(65) 6445-3033

#### South Korea

Honeywell Korea Co Ltd  
Phone: +(822) 799 6114  
Fax: +(822) 792 9015

### EMEA

Honeywell Process Solutions,  
Phone: + 800 12026455 or  
+44 (0) 1202645583

Email: (Sales)

[FP-Sales-Apps@Honeywell.com](mailto:FP-Sales-Apps@Honeywell.com)

or

(TAC)

[hfs-tac-support@honeywell.com](mailto:hfs-tac-support@honeywell.com)

### AMERICAS

Honeywell Process Solutions,  
Phone: (TAC) (800) 423-9883  
or (215) 641-3610  
(Sales) 1-800-343-0228

Email: (Sales)

[FP-Sales-Apps@Honeywell.com](mailto:FP-Sales-Apps@Honeywell.com)

or

(TAC)

[hfs-tac-support@honeywell.com](mailto:hfs-tac-support@honeywell.com)

### For more information

To learn more about SmartLine Transmitters,  
visit [www.honeywellprocess.com](http://www.honeywellprocess.com)  
Or contact your Honeywell Account Manager

### Process Solutions

Honeywell  
1250 W Sam Houston Pkwy S  
Houston, USA, TX 77042

Honeywell Control Systems Ltd  
Honeywell House, Skimped Hill Lane  
Bracknell, England, RG12 1EB

Shanghai City Centre, 100 Jungi Road  
Shanghai, China 20061

[www.honeywellprocess.com](http://www.honeywellprocess.com)



34-SW-03-03  
October 2018

©2018 Honeywell International Inc.